

DC BRUSHLESS FAN



CC-12032 SERIES

FEATURES

SIZE:	120×120×32 mm
BEARING TYPE:	BALL , SLEEVE & ONE BALL & ONE SLEEVE BEARING
IMPELLER:	PLASTIC WITH FIBER GLASS FILLED UL 94V-0
FRAME:	PLASTIC WITH FIBER GLASS FILLED UL 94V-0
WEIGHT:	250(g)

PERFORMANCE & DIMENSIONS

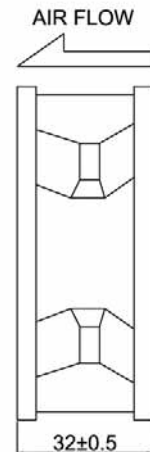
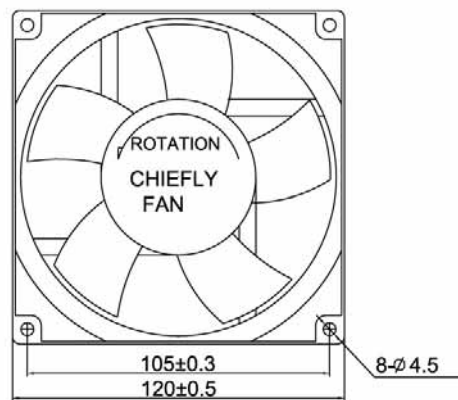
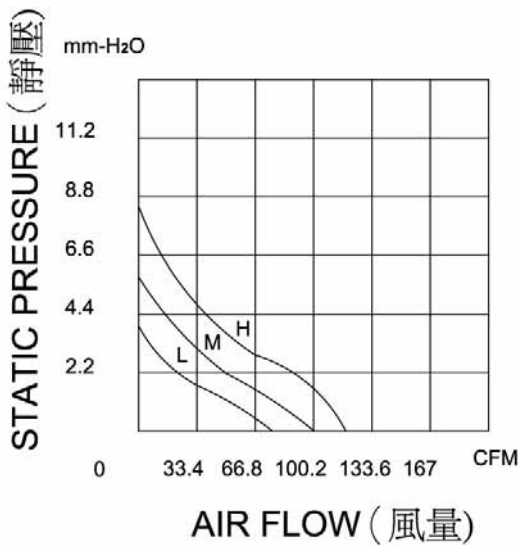

Model No.	Bearing	Rated Voltage (VDC)	Air Flow (CFM)	Current (A)	Input Power (Watts)	Speed (RPM)	Noise Level (dBA)	Dimensions
								L×W×H (mm)
CC 12032S12H	Sleeve	12	120	0.60	7.20	3750	49.8	120×120×32
CC 12032B12H	2Ball	12	120	0.60	7.20	3750	49.8	
CC 12032C12H	1B1S	12	120	0.60	7.20	3750	49.8	
CC 12032S24H	Sleeve	24	120	0.45	10.80	3750	49.8	
CC 12032B24H	2Ball	24	120	0.45	10.80	3750	49.8	
CC 12032C24H	1B1S	24	120	0.45	10.80	3750	49.8	
CC 12032S48H	Sleeve	48	120	0.23	11.00	3750	49.8	
CC 12032B48H	2Ball	48	120	0.23	11.00	3750	49.8	
CC 12032C48H	1B1S	48	120	0.23	11.00	3750	49.8	
CC 12032S12M	Sleeve	12	112	0.50	6.00	3000	46.3	
CC 12032B12M	2Ball	12	112	0.50	6.00	3000	46.3	
CC 12032C12M	1B1S	12	112	0.50	6.00	3000	46.3	
CC 12032S24M	Sleeve	24	112	0.28	6.70	3000	46.3	
CC 12032B24M	2Ball	24	112	0.28	6.70	3000	46.3	
CC 12032C24M	1B1S	24	112	0.28	6.70	3000	46.3	
CC 12032S48M	Sleeve	48	112	0.18	8.60	3000	46.3	
CC 12032B48M	2Ball	48	112	0.18	8.60	3000	46.3	
CC 12032C48M	1B1S	48	112	0.18	8.60	3000	46.3	
CC 12032S12L	Sleeve	12	95	0.32	3.80	2900	41.67	
CC 12032B12L	2Ball	12	95	0.32	3.80	2900	41.67	
CC 12032C12L	1B1S	12	95	0.32	3.80	2900	41.67	
CC 12032S24L	Sleeve	24	95	0.22	5.30	2900	41.67	
CC 12032B24L	2Ball	24	95	0.22	5.30	2900	41.67	
CC 12032C24L	1B1S	24	95	0.22	5.30	2900	41.67	
CC 12032S48L	Sleeve	48	95	0.15	7.20	2900	41.67	
CC 12032B48L	2Ball	48	95	0.15	7.20	2900	41.67	
CC 12032C48L	1B1S	48	95	0.15	7.20	2900	41.67	