

AC AXIAL FAN

CC-8038 SERIES

FEATURES



SIZE:	80×80×38 mm
BEARING TYPE:	BALL BEARING & SLEEVE BEARING
IMPELLER:	PLASTIC WITH FIBER GLASS FILLED UL 94V-0
FRAME:	DIE CAST ALUMINUM
WEIGHT:	370(g)

PERFORMANCE & DIMENSIONS

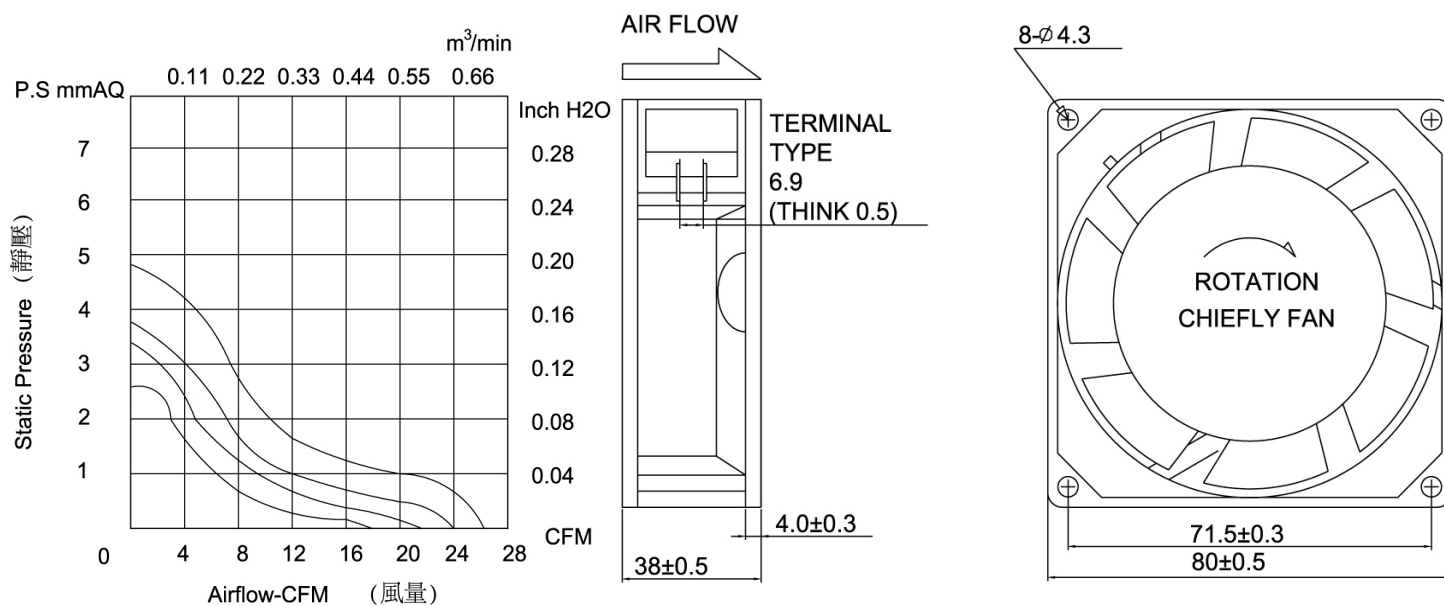

Model No.	Bearing	Rated Voltage (VAC)	Freq (Hz)	Current (A)	Input Power (Watts)	Speed (RPM)	Air Flow (CFM)	Noise Level (dBA)
CC 8038S110H	Sleeve	110/120	50/60	0.14/0.12	14	2800	27/30	30/35
CC 8038B110H	Ball	110/120	50/60	0.14/0.12	14	2800	27/30	30/35
CC 8038S220H	Sleeve	220/240	50/60	0.10/0.08	14	2800	27/30	30/35
CC 8038B220H	Ball	220/240	50/60	0.10/0.08	14	2800	27/30	30/35
CC 8038S110M	Sleeve	110/120	50/60	0.12/0.10	11	2600	22/26	24/27
CC 8038B110M	Ball	110/120	50/60	0.12/0.10	11	2600	22/26	24/27
CC 8038S220M	Sleeve	220/240	50/60	0.08/0.06	11	2600	22/26	24/27
CC 8038B220M	Ball	220/240	50/60	0.08/0.06	11	2600	22/26	24/27
CC 8038S110L	Sleeve	110/120	50/60	0.10/0.08	7	2200	18/20	21/23
CC 8038B110L	Ball	110/120	50/60	0.10/0.08	7	2200	18/20	21/23
CC 8038S220L	Sleeve	220/240	50/60	0.06/0.04	7	2200	18/20	21/23
CC 8038B220L	Ball	220/240	50/60	0.06/0.04	7	2200	18/20	21/23